

IPH Series IP Pump

3.6 to 125.9cm³/rev
30MPa

❖ This is a new design series in which all pump types are installation compatible with previous designs. Note, however, that there is no longer compatibility for some of the seal components between the IPH-3 and IPH-4 sizes and design numbers 10 and 12.

Features

- ① A patented axial and radial pressure loading system provides high efficiency and generates pressures up to 30MPa {306kgf/cm²}.
- ② Outstanding durability and very long life.
- ③ A modified involute short-tooth gear enables internal gearing for greatly reduced pulsation and noise, and exceptionally quiet operation.
- ④ A simple structure makes maintenance and inspection easier.

Specifications

Model No.	Capacity cm ³ /rev	Rated Voltage MPa	Maximum Operating Pressure MPa(kgf/cm ²)	Minimum Revolution Speed min ⁻¹	Maximum Revolution Speed min ⁻¹	Weight kg	
						Type A	Type B
IPH-2A(B)- 3.5-11	3.60	25 {255}	30 {306}	600	2000	4.4	2.4
	5					4.5	2.5
	6.5					4.6	2.6
	8					4.8	2.8
IPH-3A(B)- 10-20	10.2	25 {255}	30 {306}	600	2000	10.5	4.8
	13					10.7	5.0
	16					11.0	5.3
IPH-4A(B)- 20-20	20.7	25 {255}	30 {306}	500	2000	15.2	9.5
	25					15.7	10.0
	32					16.2	10.5
IPH-5A(B)- 40-21(11)	40.8	25 {255}	30 {306}	400	2000	32.0	19.0
	50					33.0	20.0
	64					34.0	21.0
IPH-6A(B)- 80-21(11)	81.3	25 {255}	30 {306}	300	2000	62.0	39.0
	100					64.0	41.0
	125					66.0	43.0

- Note) 1.Capacity: Logical discharge rate per rotation.
 2.Suction Pressure: +0.03 to +0.3MPa {-0.3 to +0.3kgf/cm²}
 3.Maximum working pressure shown here is the pressure limit when there are frequent pressure changes.
 4.Avoid installation with the suction port towards the bottom of the pump.
 5.Specify using the model number format shown below when pipe flanging is required.

● Handling

- ① For the hydraulic operating fluid, use an R&O type and wear-resistant type of ISO VG32 to 68 or equivalent (viscosity index of at least 90). Use hydraulic operating fluid that provides kinematic viscosity during operation in the range of 20 to 150mm²/s.
- ② The operating temperature range is 5 to 65°C. When the oil temperature at

startup is 5°C or less, perform a warm-up operation at low pressure until the oil temperature reaches 5°C. Use the pump in an area where the temperature is within the range of 0 to 60°C.

- ③ Suction pressure is -0.03 to +0.03MPa (-0.3 to +0.3kgf/cm²), and the suction port flow rate should be to greater than 2m/sec.
- ④ Avoid pulley, gear, and other drive systems that impart a radial or thrust load on the end of the pump shaft.
- ⑤ Mount the hydraulic pump so its pump shaft is oriented horizontally. Provide a suction strainer with a filtering grade of about 100μm (150 mesh). For the return line to the tank, use a 25μm line filter.
- ⑥ Manage hydraulic operating fluid so contamination is maintained at class NAS10 or lower. Take care to avoid contamination with water and other foreign matter, and watch out for discoloration. Whitish fluid indicates that air has contaminated the fluid, and brownish fluid indicates the fluid is dirty.

Understanding Model Numbers

IPH - 4 B - 25 - LT - 20

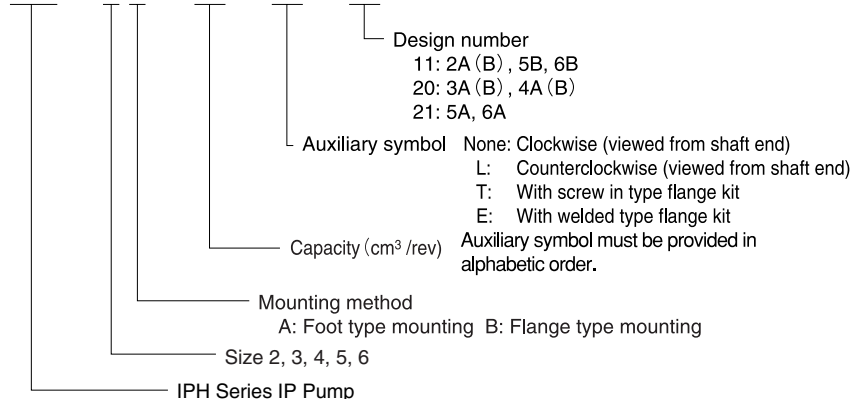

(Continued on following page)

- 7 When using water- or glycol-based hydraulic operating fluid, refer to page O-3 for details on applicable models of hydraulic pumps.
- 8 At startup, repeat the inching operation (start-stop) to bleed air from the pump and pipes.
- 9 Equip an air bleed valve in circuits

- where it is difficult to bleed air before startup. See page C-13 for more information.
- 10 To ensure proper lubrication of the pump's rubbing surfaces, supply oil to the interior of the pump before starting operation.
- 11 When centering the pump shaft,

- eccentricity with the motor shaft should be no greater than 0.05mm. Use a pump mounting base of sufficient rigidity. The angle error should be no greater than 1°.
- 12 Contact your agent for information about engines.

Discharge Rate and Required Input for Each Pump Speed

Speed	Pressure MPa Model No.	Discharge Rate ℓ /min						Required Input kW					
		0.7	7	14	21	25	30	0.7	7	14	21	25	30
1000 min ⁻¹	IPH-2A(B)- 3.5-11 5 6.5 8	3.60 5.24 6.55 8.18	3.49 5.09 6.37 7.95	3.39 4.93 6.19 7.74	3.28 4.78 6.03 7.54	3.23 4.70 5.93 7.40	3.15 4.60 5.82 7.26	0.09 0.12 0.16 0.19	0.62 0.79 0.97 1.19	1.12 1.47 1.82 2.24	1.63 2.26 2.79 3.45	1.93 2.63 3.25 4.01	2.30 3.19 3.95 4.86
	IPH-3A(B)- 10-20 13 16	10.2 13.3 15.8	9.95 13.0 15.4	9.71 12.7 15.1	9.47 12.4 14.8	9.23 12.3 14.6	9.17 12.1 14.3	0.25 0.32 0.37	1.59 2.02 2.37	2.73 3.57 4.23	4.25 5.35 6.35	5.06 6.29 7.47	6.14 7.73 9.19
	IPH-4A(B)- 20-20 25 32	20.7 25.7 32.3	20.2 25.2 31.6	19.8 24.7 31.0	19.3 24.2 30.4	19.1 23.9 30.1	18.8 23.6 29.6	0.50 0.61 0.75	3.13 3.79 4.71	5.56 6.89 8.67	8.24 10.3 12.8	9.80 12.1 15.3	11.7 14.6 18.4
	IPH-5A(B)- 40-21(11) 50 64	40.8 50.3 63.9	39.9 49.3 62.6	39.0 48.4 61.4	38.1 47.3 60.2	37.6 46.8 59.5	37.0 46.2 58.6	0.99 1.20 1.49	6.18 7.42 9.32	10.9 13.6 17.2	16.3 20.1 25.5	19.3 23.8 30.6	23.8 28.6 36.3
	IPH-6A(B)- 80-21(11) 100 125	81.3 101.6 125.9	79.5 99.6 123.4	77.7 97.7 121.1	76.0 95.8 118.7	75.1 94.6 117.2	73.8 93.2 115.6	1.98 2.42 2.94	11.8 14.6 17.8	21.8 27.3 33.9	32.3 40.5 50.1	38.4 48.1 59.6	46.7 57.7 71.5
1200 min ⁻¹	IPH-2A(B)- 3.5-11 5 6.5 8	4.32 6.28 7.86 9.81	4.20 6.12 7.67 9.58	4.08 5.95 7.48 9.34	3.97 5.79 7.29 9.11	3.91 5.70 7.18 8.97	3.83 5.58 7.05 8.81	0.11 0.15 0.19 0.23	0.66 0.95 1.16 1.44	1.23 1.77 2.19 2.70	1.83 2.62 3.24 4.00	2.15 3.09 3.81 4.70	2.61 3.74 4.63 5.71
	IPH-3A(B)- 10-20 13 16	12.2 15.9 18.9	11.9 15.9 18.5	11.7 15.3 18.2	11.4 15.0 17.8	11.3 14.8 17.6	11.1 14.6 17.4	0.30 0.39 0.45	1.86 2.37 2.77	3.28 4.28 5.09	4.93 6.42 7.63	5.93 7.56 8.98	7.20 9.28 11.1
	IPH-4A(B)- 20-20 25 32	24.8 30.8 38.7	24.3 30.3 38.1	23.8 29.8 37.4	23.4 29.3 36.8	23.1 29.0 36.3	22.8 28.6 35.9	0.62 0.75 0.92	3.76 4.56 5.66	6.67 8.27 10.4	9.88 12.3 15.5	11.8 14.7 18.4	14.2 17.5 22.0
	IPH-5A(B)- 40-21(11) 50 64	48.9 60.3 76.6	48.0 59.3 75.3	47.1 58.3 74.0	46.1 57.3 72.8	45.5 56.6 72.0	44.9 56.0 71.2	1.22 1.47 1.83	7.42 8.91 11.2	13.2 16.2 20.6	19.5 24.0 30.5	23.1 28.6 36.3	28.4 34.3 43.5
	IPH-6A(B)- 80-21(11) 100 125	97.5 121.9 151.0	95.7 119.7 148.4	93.8 117.7 145.9	91.9 115.8 143.4	90.9 114.5 141.9	89.5 113.1 140.3	2.42 2.96 3.60	14.3 17.5 21.5	26.2 32.3 40.1	38.7 48.4 60.1	46.2 57.7 71.6	56.1 69.2 85.9
1500 min ⁻¹	IPH-2A(B)- 3.5-11 5 6.5 8	5.40 7.86 9.82 12.3	5.25 7.65 9.59 11.9	5.10 7.44 9.35 11.6	4.97 7.24 9.12 11.4	4.89 7.11 8.97 11.2	4.79 6.97 8.82 11.0	0.14 0.20 0.25 0.30	0.96 1.17 1.49 1.78	1.68 2.21 2.73 3.37	2.46 3.31 4.09 5.05	2.89 3.85 4.76 5.87	3.46 4.69 5.78 7.14
	IPH-3A(B)- 10-20 13 16	15.3 19.9 23.7	14.9 19.5 23.2	14.6 19.1 22.7	14.3 18.8 22.3	14.1 18.6 22.1	13.9 18.3 21.8	0.40 0.51 0.59	2.31 2.95 3.46	4.15 5.41 6.42	6.22 8.03 9.53	7.40 9.44 11.2	8.99 11.6 13.8
	IPH-4A(B)- 20-20 25 32	31.0 38.5 48.4	30.4 37.8 47.6	29.8 37.2 46.8	29.3 36.6 45.9	28.9 36.1 45.4	28.4 35.7 44.9	0.81 0.98 1.20	4.70 5.69 7.07	8.33 10.4 13.1	12.4 15.4 19.3	14.7 18.3 22.9	17.6 21.9 27.5
	IPH-5A(B)- 40-21(11) 50 64	61.2 75.4 95.8	60.0 74.1 94.2	58.8 72.8 92.5	57.6 71.6 91.0	56.9 70.8 90.0	56.2 70.0 89.0	1.59 1.91 2.38	9.51 11.4 14.4	16.6 20.5 26.0	24.7 30.4 38.6	29.3 36.1 45.9	36.0 43.3 55.1
	IPH-6A(B)- 80-21(11) 100 125	121.9 152.4 188.8	119.5 149.7 185.5	117.3 147.3 182.5	115.0 144.7 179.3	113.5 143.2 177.5	111.9 141.5 175.3	3.16 3.86 4.69	18.3 22.5 27.5	33.1 41.4 51.3	49.0 61.4 76.0	58.4 73.0 90.4	70.9 87.6 108.1
1800 min ⁻¹	IPH-2A(B)- 3.5-11 5 6.5 8	6.48 9.43 11.7 14.7	6.33 9.21 11.5 14.4	6.16 8.99 11.2 14.1	6.01 8.76 11.0 13.7	5.92 8.61 10.9 13.6	5.82 8.46 10.7 13.3	0.17 0.24 0.30 0.37	1.16 1.45 1.78 2.20	2.02 2.65 3.27 4.04	2.95 3.47 4.92 6.06	3.46 4.62 5.71 7.05	4.15 5.61 6.93 8.56
	IPH-3A(B)- 10-20 13 16	18.3 23.9 28.4	18.0 23.5 27.9	17.6 23.1 27.5	17.3 22.7 27.0	17.1 22.5 26.7	16.8 22.2 26.4	0.49 0.62 0.72	2.90 3.67 4.30	5.04 6.57 7.80	7.47 9.63 11.4	8.89 11.3 13.5	10.8 13.9 16.5
	IPH-4A(B)- 20-20 25 32	37.2 46.2 58.1	36.6 45.6 57.3	36.0 44.9 56.5	35.4 44.3 55.5	35.0 43.8 55.1	34.5 43.3 54.5	0.99 1.20 1.48	5.64 6.83 8.47	10.0 12.4 15.6	14.9 18.5 23.1	17.6 21.9 27.5	21.2 26.3 33.0
	IPH-5A(B)- 40-21(11) 50 64	73.4 90.5 115.0	72.1 89.2 113.4	70.9 87.9 111.6	69.7 86.6 110.0	69.0 85.9 109.1	68.1 85.0 108.0	1.95 2.34 2.92	11.7 14.1 17.6	20.2 24.9 31.6	30.0 36.9 46.8	35.6 43.8 55.7	43.7 52.6 66.9
	IPH-6A(B)- 80-21(11) 100 125	146.3 182.8 226.6	143.7 180.2 223.3	141.4 177.6 220.1	139.0 174.9 216.9	137.5 173.5 215.0	135.8 171.7 212.7	3.88 4.74 5.75	22.4 27.7 33.8	40.2 50.3 62.2	59.6 74.4 92.3	70.9 88.6 110.0	86.1 106.0 131.5

Note) Values in the table are general values at an operating fluid viscosity of 46mm²/s. Use the values when selecting the model for your needs.

Installation Dimension Drawings

IPH-2A-*-11 (Foot Mounting, Clockwise Rotation)

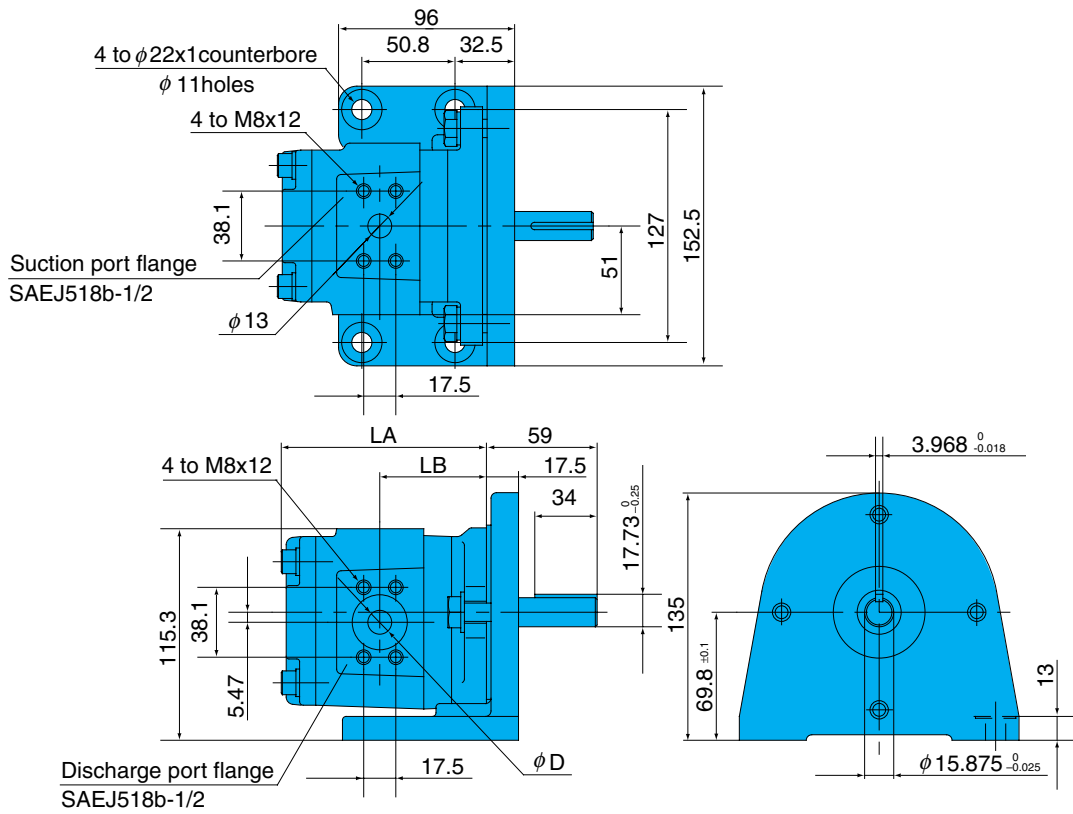

IPH-2B-*-11 (Flange Mounting, Clockwise Rotation)

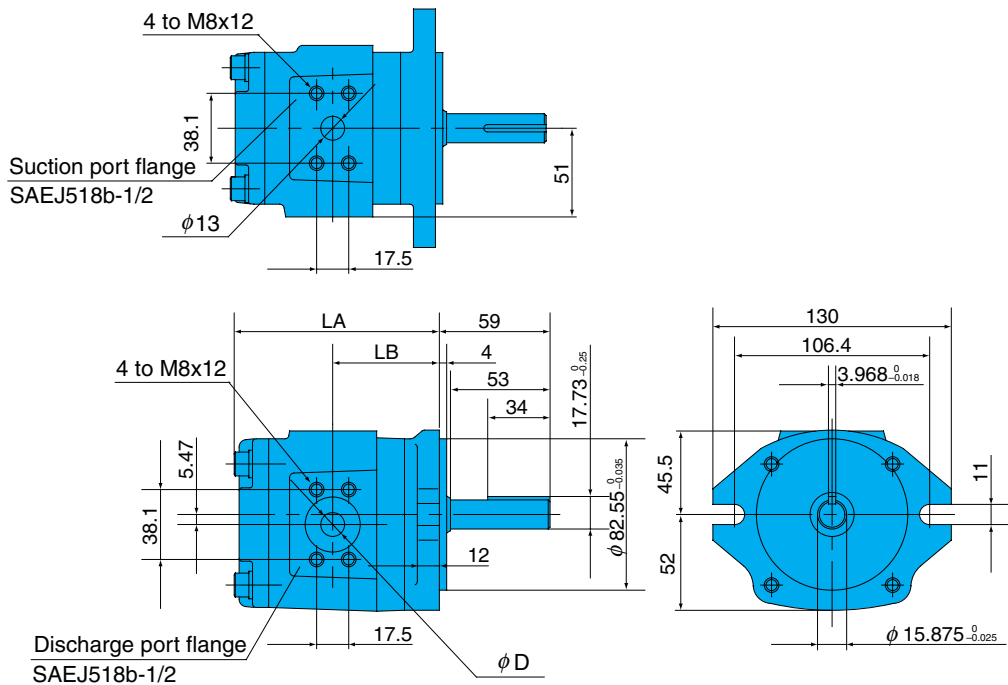

Model No.	Dimensions (mm)		
	LA	LB	ϕD
IPH-2*-3.5-*-11	107	51.0	8.9
IPH-2*-5-*-11	112	53.5	11
IPH-2*-6.5-*-11	116	55.5	12
IPH-2*-8-*-11	121	58.0	13

Note) IPH-2A (B)-*-L-11 (foot mounting/flange mounting, counterclockwise rotation) are the mirror image of the drawings shown above. In the case the suction port flange is facing upwards, the discharge port flange is positioned to the right when viewed from the shaft side.



IPH-3A-*-20 (Foot Mounting, Clockwise Rotation)

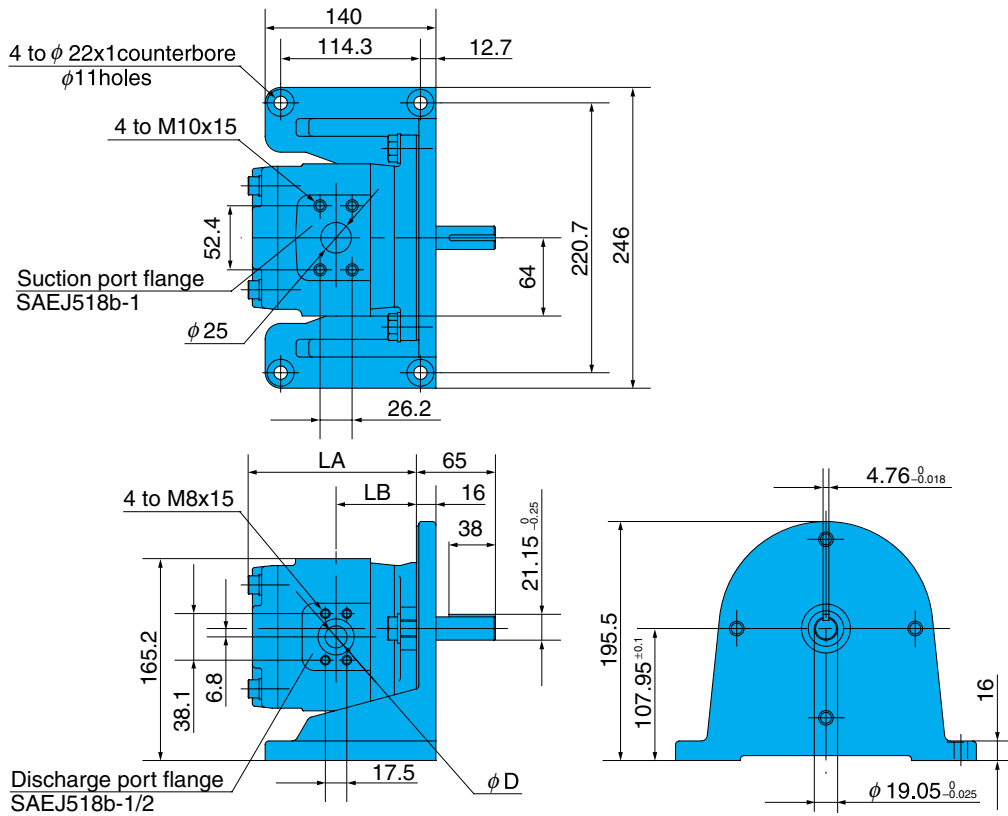

IPH-3B-*-20 (Flange Mounting, Clockwise Rotation)

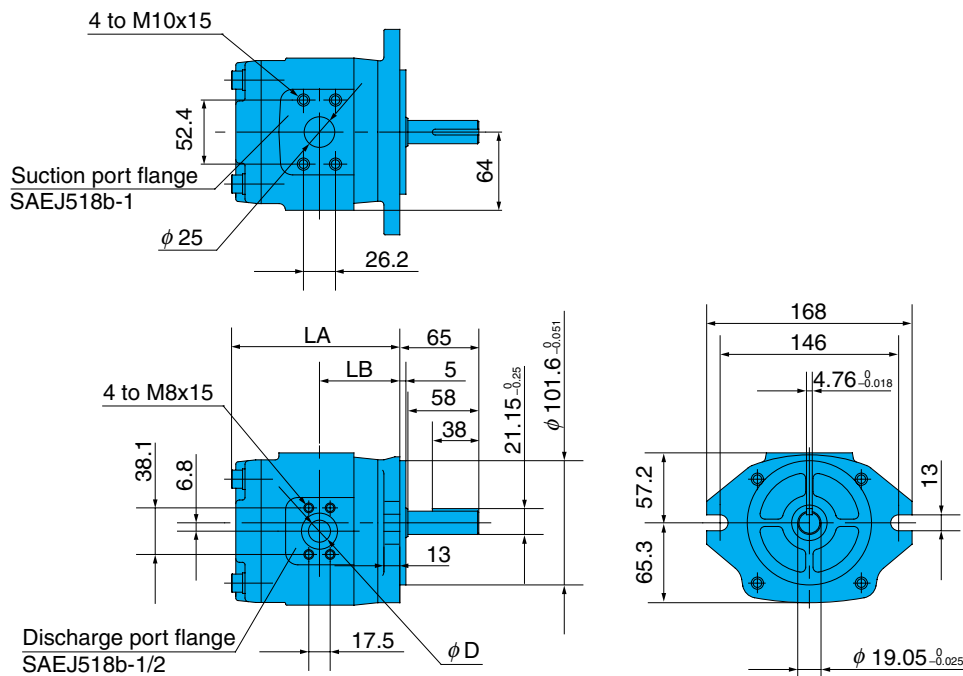

Model No.	Dimensions (mm)		
	LA	LB	φD
IPH-3*-10-*-20	128.5	60.0	14
IPH-3*-13-*-20	134.5	63.0	17
IPH-3*-16-*-20	139.5	65.5	18

Note) IPH-3A (B)-*-L-20 (foot mounting/flange mounting, counterclockwise rotation) are the mirror image of the drawings shown above. In the case the suction port flange is facing upwards, the discharge port flange is positioned to the right when viewed from the shaft side.

IPH-4A-*-20 (Foot Mounting, Clockwise Rotation)

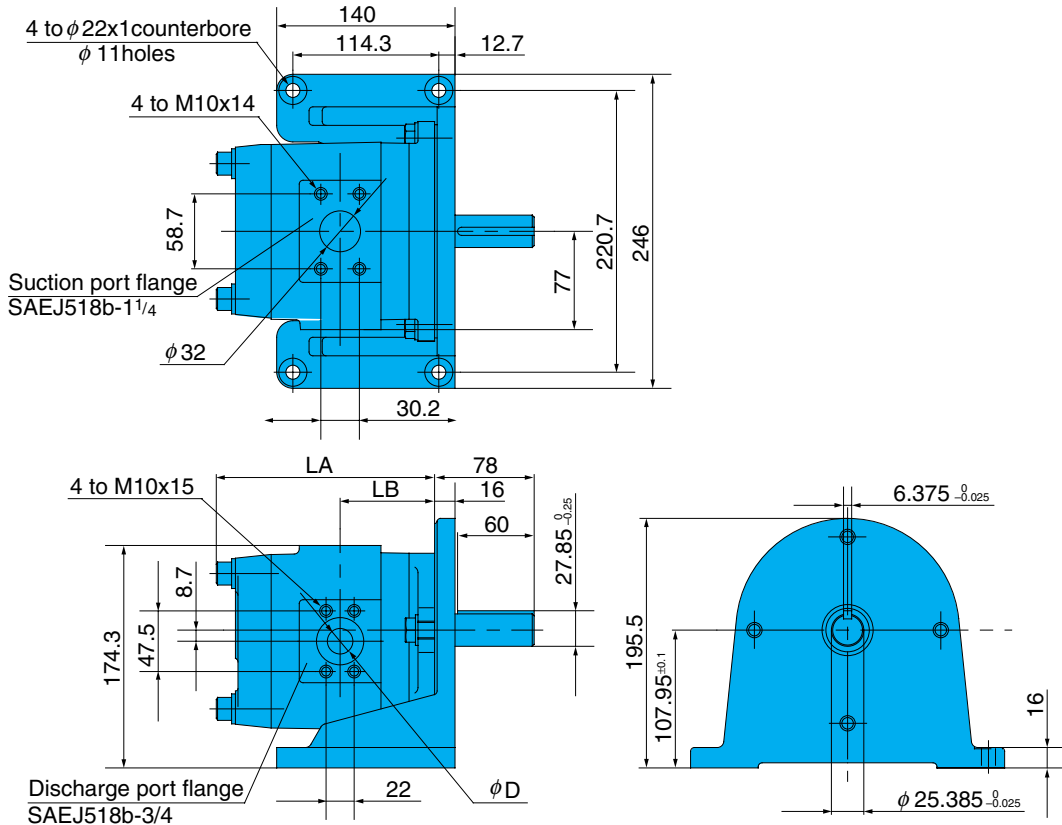

IPH-4B-*-20 (Flange Mounting, Clockwise Rotation)

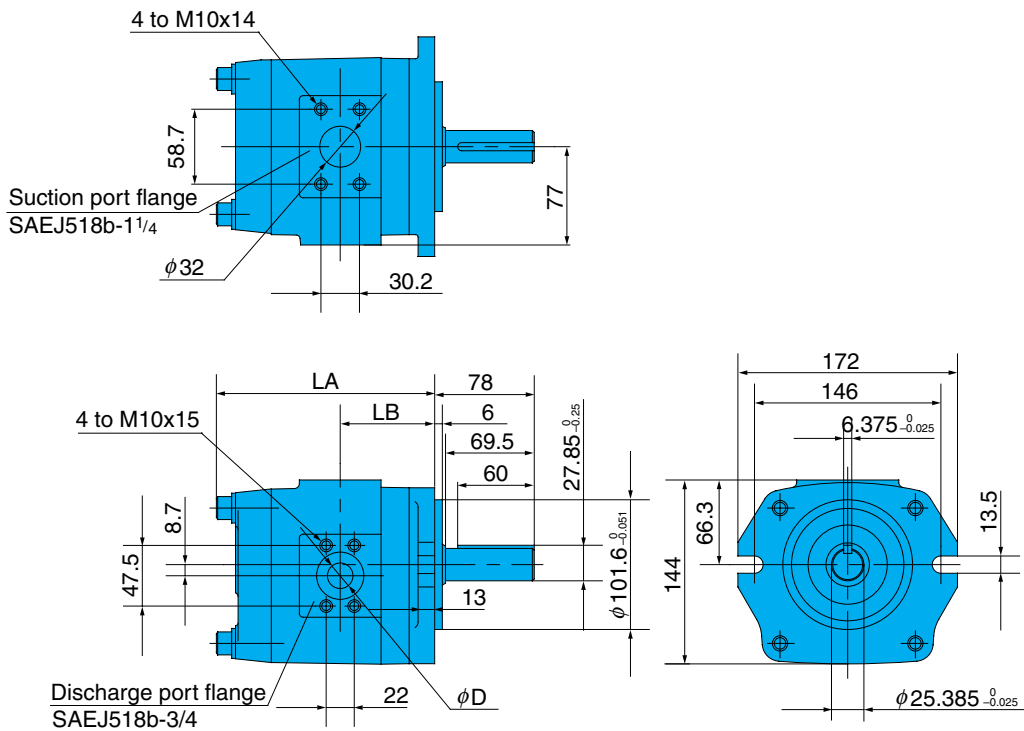

Model No.	Dimensions (mm)		
	LA	LB	ϕD
IPH-4*-20-*-20	164.5	71	18
IPH-4*-25-*-20	170.5	74	20
IPH-4*-32-*-20	178.5	78	24

Note) IPH-4A (B)-*-L-20 (foot mounting/flange mounting, counterclockwise rotation) are the mirror image of the drawings shown above. In the case the suction port flange is facing upwards, the discharge port flange is positioned to the right when viewed from the shaft side.

IPH-5A-*-21 (Foot Mounting, Clockwise Rotation)

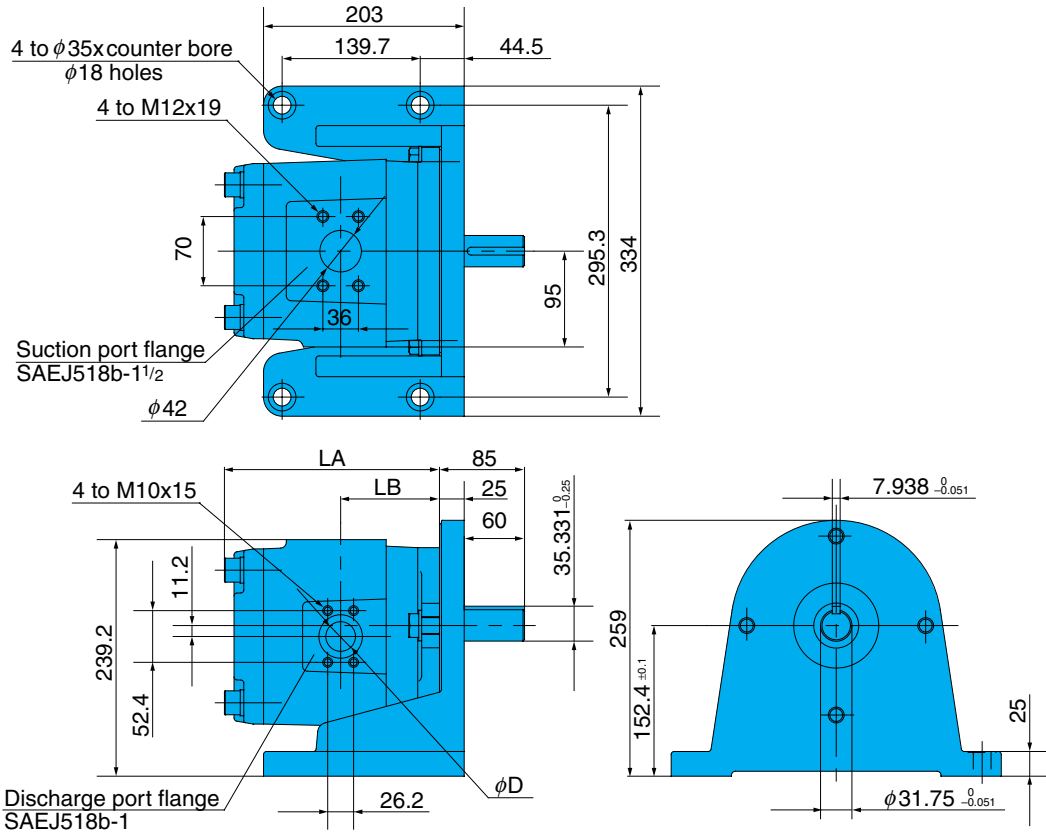

IPH-5B-*-11 (Flange Mounting, Clockwise Rotation)

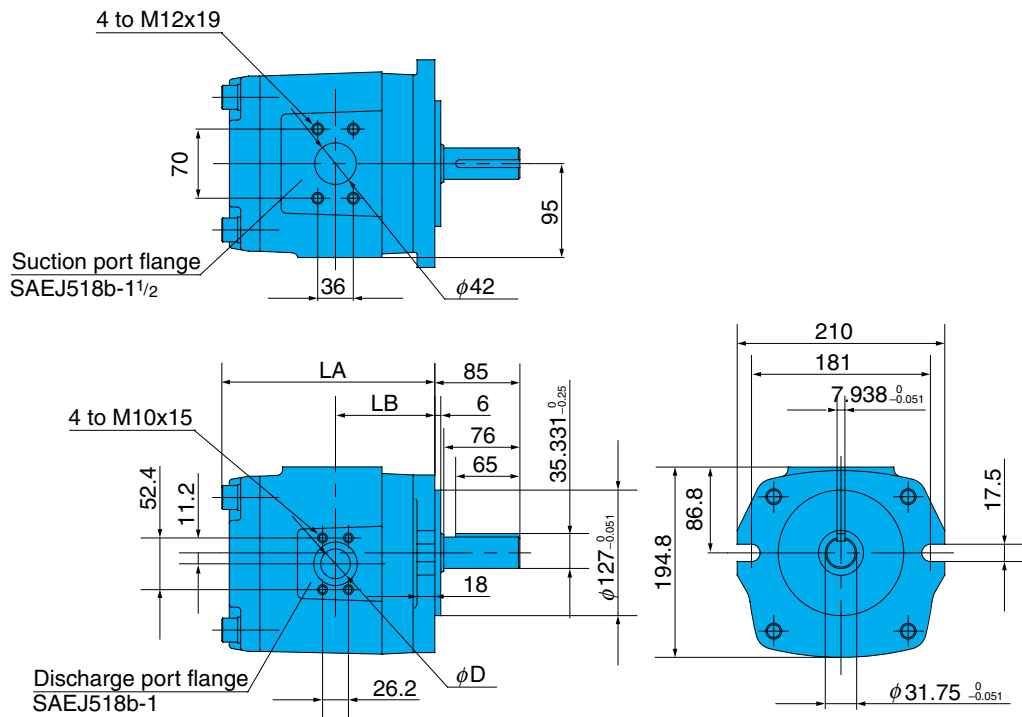

Model No.	Dimensions (mm)		
	LA	LB	ϕD
IPH-5*-40-*-21 (11)	201.5	91.0	24
IPH-5*-50-*-21 (11)	208.5	94.5	26
IPH-5*-64-*-21 (11)	218.5	99.5	28

Note) IPH-5A (B)-*-L-21 (11) (foot mounting/flange mounting, counterclockwise rotation) are the mirror image of the drawings shown above. In the case the suction port flange is facing upwards, the discharge port flange is positioned to the right when viewed from the shaft side.

IPH-6A-*-21 (Foot Mounting, Clockwise Rotation)

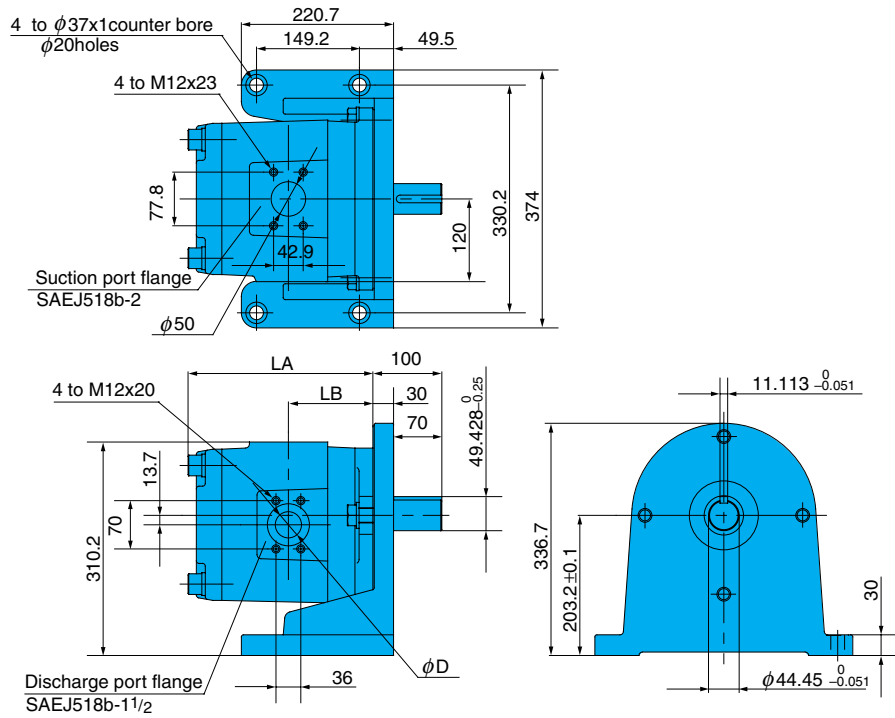

IPH-6B-*-11 (Flange Mounting, Clockwise Rotation)

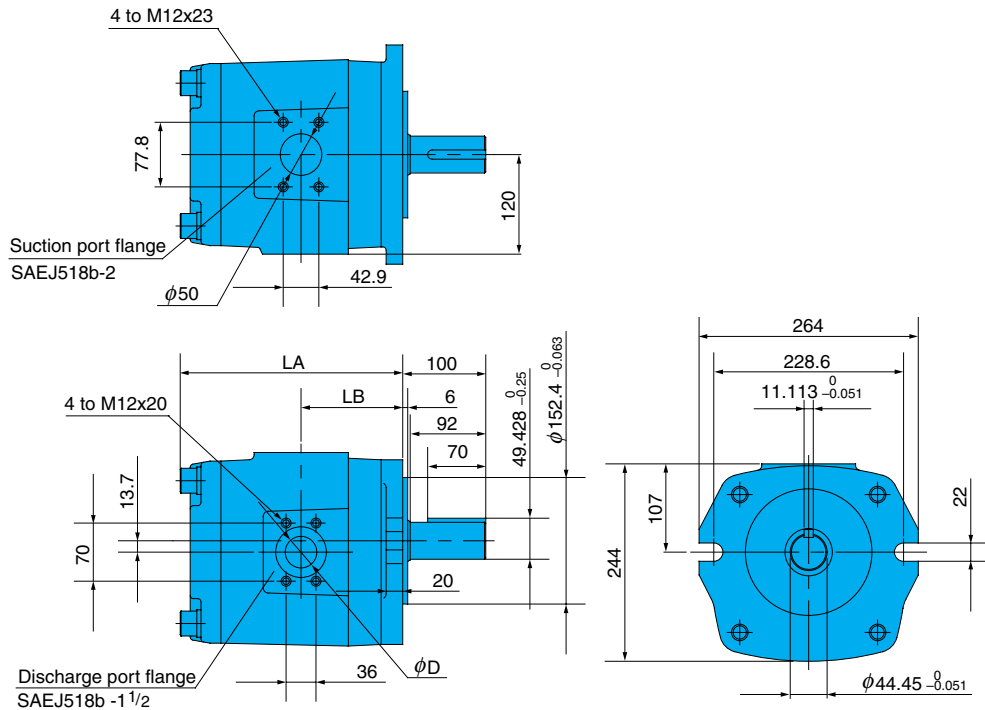

Model No.	Dimensions (mm)		
	LA	LB	ϕD
IPH-6*- 80-*-21 (11)	241.5	111.5	32
IPH-6*-100-*-21 (11)	251.5	116.5	36
IPH-6*-125-*-21 (11)	263.5	122.5	38

Note) IPH-6A (B)-*-L-21 (11) (foot mounting/flange mounting, counterclockwise rotation) are the mirror image of the drawings shown above. In the case the suction port flange is facing upwards, the discharge port flange is positioned to the right when viewed from the shaft side.

Performance Curves

Revolution Speed 1200min⁻¹
 Operating Hydraulic Fluid Viscosity 46mm²/s
 Representative Characteristics Under Above Conditions

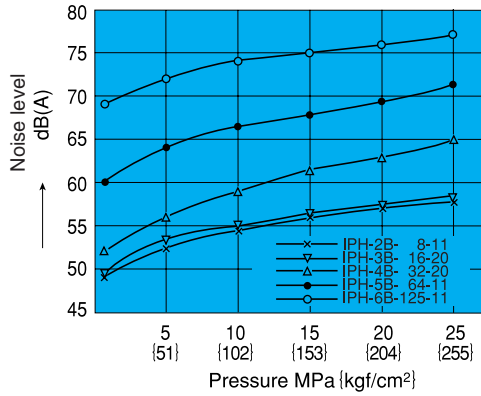
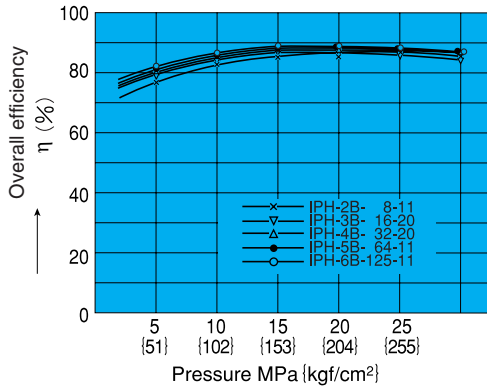
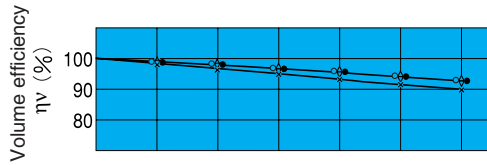

Cross-sectional Drawing

IPH-*B-*

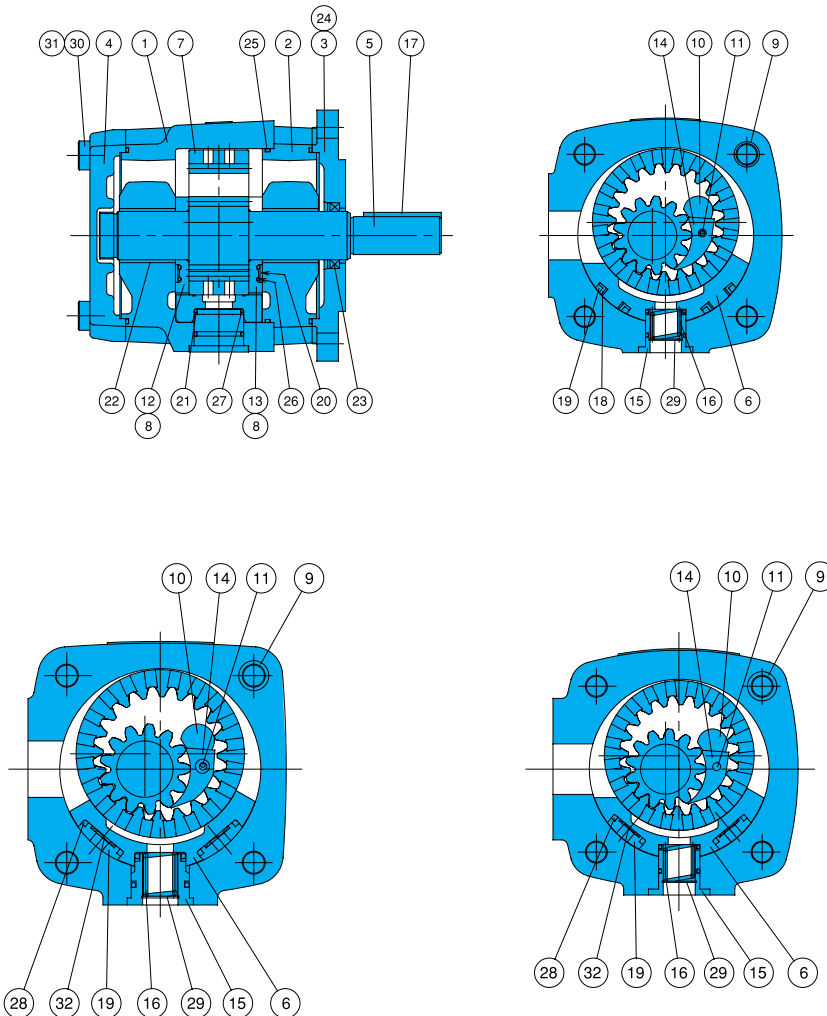

Part No.	Part Name
1	Body -1
2	Body -2
3	Mounting
4	Rear cover
5	Pinion shaft
6	Radial piston
7	Internal gear
8	Bushing
9	Knock pin
10	Stopper pin
11	Spring pin (guide pin)
12	Axial plate -1
13	Axial plate -2
14	Feeler piece
15	Spring holder
16	Spring
17	Key
18	Radial seal
19	Radial backup ring
20	Axial backup ring
21	Backup ring
22	Bearing
23	Oil seal
24	Pin
25	O-ring
26	O-ring
27	O-ring
28	O-ring
29	Snap ring
30	Screw
31	Washer
32	Wave washer